

TOPTUL[®]

THE MARK OF PROFESSIONAL TOOLS

TOPTUL TAIWAN

Rotar Machinery Industrial Co., Ltd.

No.189, Gongye Rd., Taiping Dist., Taichung City 41154

(Ta Li Ind. Park), Taiwan

Tel:+886-4-22715989 (Rep)

Fax:+886-4-22716979

E-mail:service@toptul.com

Website:www.toptul.com



KA-0205A

TOPTUL[®]

THE MARK OF PROFESSIONAL TOOLS



Professional Grade Air Tools

Air Hydraulic Riveter

▶ Part No. KARA0205

Operational Manual



Professional Grade Air Tools

Air Hydraulic Riveter

TOPTUL SUPER DUTY AIR HYDRAULIC RIVETER

Read and understand the owner's manual and labels affixed to the tool. Learn its application and limitations as well as the specific potential hazards peculiar to this tool.

Operation Guides

TIPS FOR USE:

(Safety Regulations while using **TOPTUL** brand Pneumatic Tools)

1. Testing

The tool is well assembled and tested before delivery; however the necessary setting and testing are still strongly suggested before operating tool.

2. Setting

The compressed air pressure should be in the suggested working range; tool's working nosepiece size, blind rivet size and work pieces' hole diameter must be well matched, so that the pilot test can verify the fastening work is correct or not.

3. Air Pressure

This pneumatic-hydraulic rivet tool is operated with compressed air at an optimum air pressure of 6.2 bar or 90 psi. The air pressure regulator is used to adjust the operating air pressure not to exceed the maximum operating air pressure 6.5 bar or 95 psi.

4. Air Supply System

This pneumatic-hydraulic rivet tool is recommended to connect with COMPRESSED AIR SUPPLY SYSTEM, including air compressor, main air supply line, air preparation unit (air filter, air pressure regulator with gauge, air lubricator) and air hose. These should be fitted within 3 meters or 10 feet from air pressure regulator to the tool to ensure maximum tool life and minimum tool maintenance.

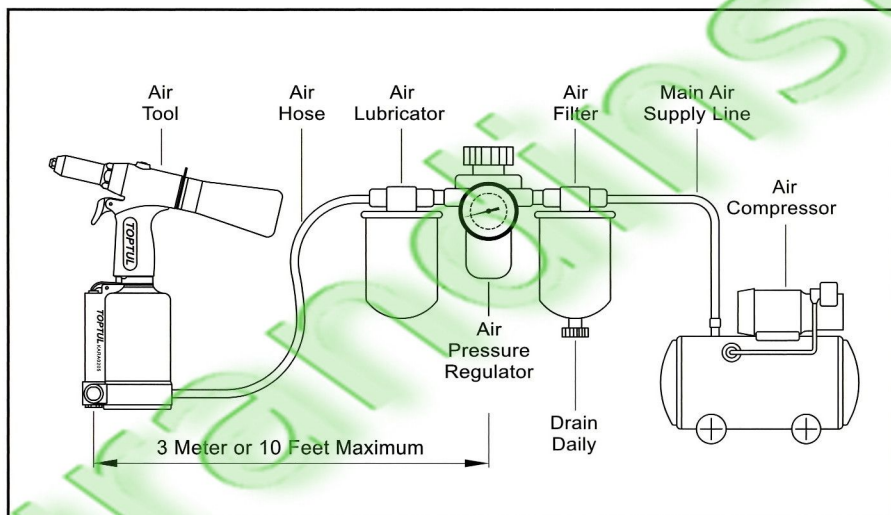

5. Air Hose

The air hose must have a minimum inner diameter of 8 mm or 5/16". Clean the hose with a blast of compressed air before connecting the hose to air tool. This will prevent both moisture and dust within the hose from entering the tool and causing possible rust or malfunction.



6. Inserted Tools

Use only sizes and types of accessories and consumables that are recommended by the manufacturer of assembly power tool; do not use other types or sizes of accessories or consumables. Any other use is forbidden.



7. Personal Protection Equipment

The approved eye and hearing protector, mouth-muffle and safety gloves shall be worn when operating this tool.



8. Always when using the tool, adopt a firm footing and/or position and grip the tool sufficiently only to overcome any reaction forces that may result from the tool doing work. Do not over grip.



9. If the tool is to be used with a balancer or other suspension device, ensure that the tool is firmly attached to the suspension/support device.



10. Always shut off the air supply to the tool and press the on/off valve to exhaust the air from the feed hose before fitting, removing or adjusting the working attachment fitted to the tool.



11. Be aware of entanglement of the moving parts of the tool with clothing, neckties, long hair, jewelry, watches and etc. This could cause the body or parts of the body to be drawn towards and in contact with the moving parts of the tool and may be very dangerous.



12. Be aware of the exhaust air does not point towards any other person or material that could be contaminated by oil droplets.

13. This tool is not electrically insulated. Never use the tool if there is any chance of coming into contact with live electricity.

14. Do not lay the tool down until the working attachment has stopped moving completely.

15. The working place shall be ventilating.

16. Release the on-off device in case of air supply failure.

17. Release the start and stop device in case of energy supply failure.

18. Use only the lubricant recommended by the manufacturer.

Air Hydraulic Riveter

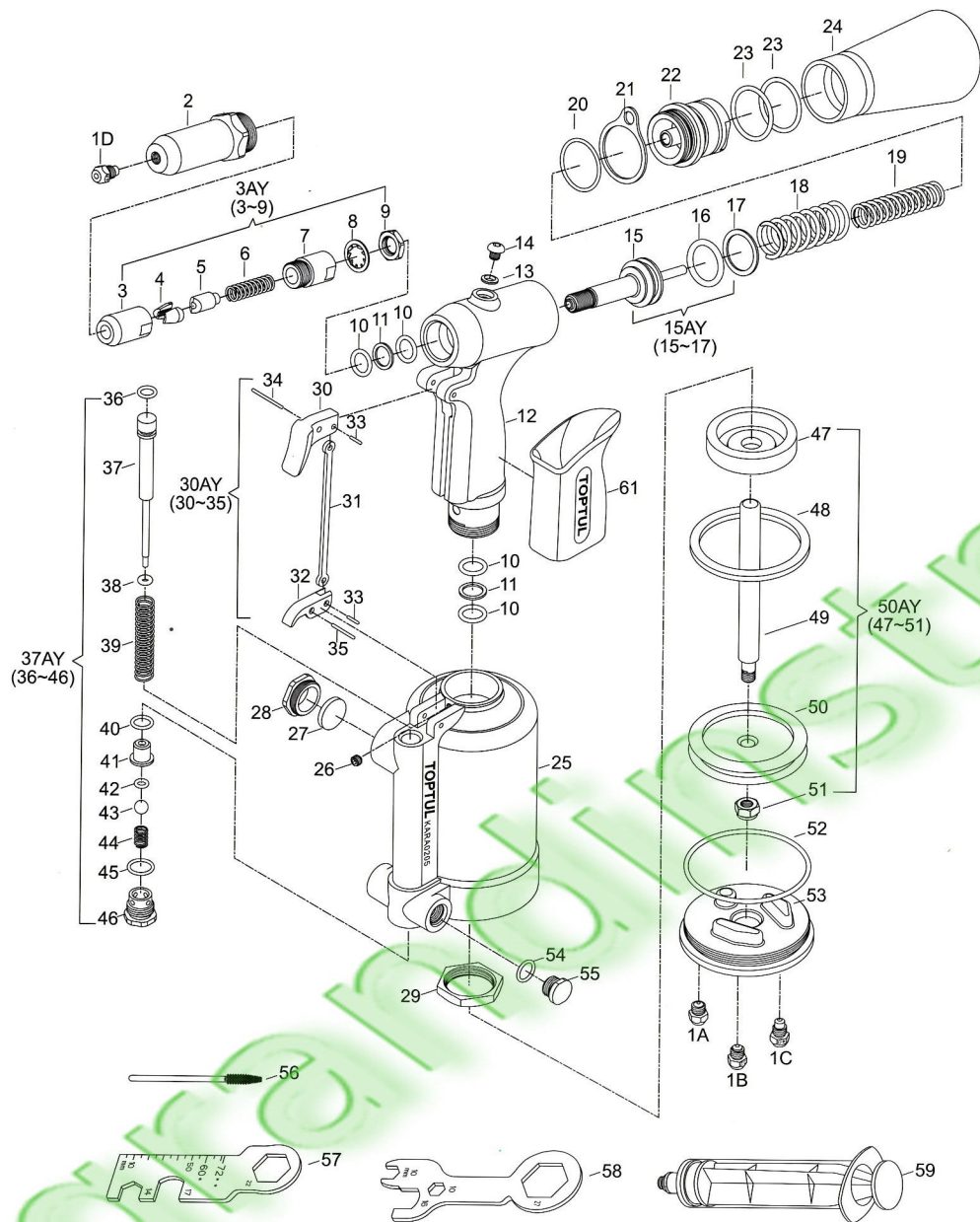

ITEM NO. **KARA0205**

Index No.	Parts No.	Description	Q'TY	Index No.	Parts No.	Description	Q'TY
● 1A	KCEB001A	Nosepiece 2.4mm or 3/32"	1	● 34	KCEB0340	Trigger Pin	1
● 1B	KCEB001B	Nosepiece 3.0/3.2mm or 1/8"	1	● 35	KCEB0350	Lever Pin	1
● 1C	KCEB001C	Nosepiece 4.0mm or 5/32"	1	● 36	KCEB0360	Valve Pusher O-Ring	1
● 1D	KCEB001D	Nosepiece 4.8/5.0mm or 3/16"	1	37	KCEB0370	Valve Pusher	1
2	KCEB0020	Head	1	● 38	KCEB0380	Valve Pusher O-Ring	1
3	KCEB0030	Front Jaw Case	1	39	KCEB0390	Valve Pusher Spring	1
● 4	KCEB0040	Jaws	2	● 40	KCEB0400	Valve Sleeve O-Ring	1
● 5	KCEB0050	Jaw Pusher	1	41	KCEB0410	Valve Sleeve	1
● 6	KCEB0060	Jaw Pusher Spring	1	● 42	KCEB0420	Valve Ball O-Ring	1
7	KCEB0070	Rear Jaw Case	1	43	KCEB0430	Valve Ball	1
8	KCEB0080	Lock Washer	1	44	KCEB0440	Valve Spring	1
9	KCEB0090	Lock Nut	1	● 45	KCEB0450	Valve End Cap O-Ring	1
● 10	KCEB0100	Oil Cylinder O-Ring	4	46	KCEB0460	Valve End Cap	1
● 11	KCEB0110	Oil Cylinder Back-Up Ring	2	47	KCEB0470	Buffer Ring	1
12	KCEB0120	Oil Cylinder	1	● 48	KCEB0480	Air Piston Ring	1
13	KCEB0130	Sealing Washer	1	49	KCEB0490	Air Piston Rod	1
14	KCEB0140	Oil Screw Plug	1	50	KCEB0500	Air Piston	1
15	KCEB0150	Oil Piston	1	51	KCEB0510	Air Piston Lock Nut	1
● 16	KCEB0160	Oil Piston O-Ring	1	● 52	KCEB0520	Air Cylinder End Cap O-Ring	1
● 17	KCEB0170	Oil Piston Back-Up Ring	1	53	KCEB0530	Air Cylinder End Cap	1
● 18	KCEB0180	Large Return Spring	1	● 54	KCEB0540	Air Inlet End Cap O-Ring	1
● 19	KCEB0190	Small Return Spring	1	55	KCEB0550	Air Inlet End Cap	1
20	KCEB0200	Hanging Bracket O-Ring	1	● 56	KCEB0560	Brush	1
21	KCEB0210	Hanging Bracket	1	● 57	KCEB0570	Wrench 22	1
22	KCEB0220	Oil Cylinder End Cap	1	● 58	KCEB0580	Wrench 27	1
23	KCEB0230	Oil Cylinder End Cap O-Ring	2	● 59	KCEB0590	Hydraulic Oil Injector, No Oil	1
● 24	KCEB0240	Spent Mandrel Container	1	61	KCEB0610	Grip	1
25	KCEB0250	Air Cylinder	1	3AY	KCEB003A	Jaw Case Assembly {incl. 3.4(2). 5.6.7.8.9}	1
26	KCEB0260	Lock Screw	1	15AY	KCEB015A	Oil Piston Assembly {incl. 15.16.17}	1
● 27	KCEB0270	Noise Silencer	1	30AY	KCEB030A	Trigger Assembly {incl. 30.31.32. 33(2).34.35}	1
28	KCEB0280	Noise Silencer Lock Nut	1	37AY	KCEB037A	Valve Assembly {incl. 36.37.38.39. 40.41.42.43.44.45.46}	1
29	KCEB0290	Oil Cylinder Lock Nut	1	50AY	KCEB050A	Air Piston Assembly {incl. 47.48. 49.50.51}	1
30	KCEB0300	Trigger	1				
31	KCEB0310	Trigger Link	1				
32	KCEB0320	Trigger Lever	1				
● 33	KCEB0330	Link Pin	2				

● Means wearing parts or possible missing parts

2017.03

TOPTUL SUPER DUTY AIR HYDRAULIC RIVETER

Read and understand the owner's manual and labels affixed to the tool. Learn its application and limitations as well as the specific potential hazards peculiar to this tool.

Operational Method



1. Make sure that the Spent Mandrel Container ⑨ is fitted the oil cylinder end cap firmly.
2. Ensure that the correct Working Nosepiece ① suitable for the prepared hole of work pieces is fitted to the head firmly.
3. Connect the tool to the compressed air supply system.
4. Insert the rivet mandrel of blind rivet into the Working Nosepiece ① of head, and then insert the rivet body of blind rivet into the prepared hole of work pieces to be fastened.
5. Fully depress the Trigger ③ to break off the rivet mandrel and deform rivet body, the work pieces are firmly fastened together at the same time. If more than one depress is required, move tool and push Working Nosepiece ① to touch rivet flange, then depress the trigger again to break off rivet mandrel.
6. Release the Trigger ③ and move the Working Nosepiece ① from the fastened work pieces, tilt Head ② upwards to drop the spent mandrel into the Spent Mandrel Container ⑨.
7. The fastening cycle is completed, and the tool is ready for setting next same size blind rivet.

NOTE:

The Hanging Bracket ⑧ is designed for hanging the tool to the suspension device of assembly line to decrease the physical strain placed on the operator by the weight of tool.

Select and Exchange the Nosepieces

1. Disconnect the tool from the compressed air supply system.
2. Choose the correct size of Working Nosepiece ①.

Nosepieces Size					
	Rivet Diameter	Ø 2.4 mm	Ø 3.0/3.2 mm	Ø 4.0 mm	Ø 4.8/5.0 mm
	Rivet Material	Ø 3/32"	Ø 1/8"	Ø 5/32"	Ø 3/16"
	Aluminum	●	●	●	●
	Copper, Steel	●	●	●	●
	Stainless Steel / Inox	●	●	●	●

NOTE:

The patented RIVET SIZE HOLE GAUGE Design at the bottom of Air Cylinder End Cap ⑫ provides a great assistance of checking the rivet body diameter of the blind rivet to be fastened, find out the size marked beside the hole gauge, then choose the matched size nosepiece as the Working Nosepiece ①, so as to prevent spent mandrel from being stuck in tool after setting blind rivet. (Fig.1)

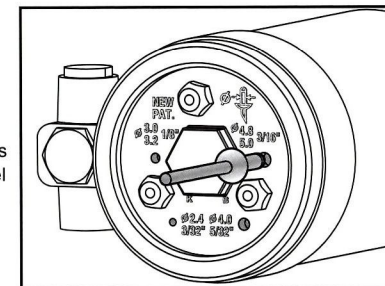

Fig.1

3. Use Wrench (Index No. 58) to exchange nosepieces. Unscrew the replaced nosepiece from the Head ② and the matched size nosepiece at the bottom of Air Cylinder End Cap ⑫.
4. Install the matched size nosepiece as the Working Nosepiece ① into the head.

Maintenance & Repairs

WARNING:

Always disconnect the tool from the COMPRESSED AIR SUPPLY SYSTEM before maintaining the tool.

NOTE:

The following operating part code refers to the explosion diagram.

Daily Checks

1. If no lubricator is fitted on the compressed air supply system, it is strongly suggested to pour a few drops of the light lubricating oil into the air inlet fitting of tool before daily operation. If the tool is in continuous use, the air inlet fitting should be lubricated every two or three hours.
2. Check for air leaks. If damaged, replace the air hoses and air couplings.
3. If there is no air filter on the compressed air supply system, bleed the air line to clear the accumulated dirt or water before connecting the air hose to the tool. If there is an air filter, drain it.

TOPTUL SUPER DUTY AIR HYDRAULIC RIVETER



Read and understand the owner's manual and labels affixed to the tool. Learn its application and limitations as well as the specific potential hazards peculiar to this tool.

- Check the JAW CASE ASSEMBLY DISTANCE that meets the specification 60 ± 0.5 mm. (Fig.2)
- Carefully check and firmly tighten the all assembly, for example the Jaw Case Assembly (3AY), Working Nosepiece (1), Head (2), Oil Screw Plug (14), Oil Cylinder End Cap (22), Noise Silencer Lock Nut (28), Valve End Cap (46), Air Cylinder End Cap (53), Air Inlet End Cap (55) and air inlet fitting before daily operation etc.
- Check to empty the spent mandrels. Be sure to fit the spent mandrel container to the oil cylinder end cap firmly.
- Check to ensure the Trigger (30) operation is normal.

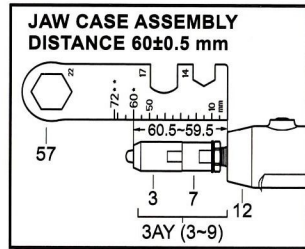

Fig.2

Weekly Checks

- Dismantle to clean the Jaw Case Assembly (3AY) with special attention to the Jaws (4), Jaw Pusher (5) and Jaw Pusher Spring (6). Use the Brush (56) to clean these parts and dip them into oil for lubrication. For better lubrication, lightly apply the moly-lithium grease on the back side of Jaws (4) and on the inner slope of Front Jaw Case (3) before reassembly. If Jaws (4) and Jaw Pusher (5) get worn out, Jaw Pusher Spring (6) becomes shorter or twisted seriously that result in malfunction, replace them.

NOTE:

If the tool is operated frequently, it is suggested to clean the jaw case assembly daily.

- Unscrew the Noise Silencer Lock Nut (28), take out the Noise Silencer (27) to clean it. See "Clean and Replace the Noise Silencer" for detailed operation.
- Check the oil leaks, and the air leaks in the compressed air supply system.

Empty the Spent Mandrel Container

When the spent mandrels fill over 70% capacity of the spent mandrel container, pull out the spent mandrel container and empty the spent mandrels. Finally, make sure to fit the spent mandrel container back to the tool firmly.

WARNING: Overfilling spent mandrels causes the tool to malfunction.

Exchange the Air Inlet Fitting to the Air Inlets

The Twin Air Inlets Design offer to meet individual operating hobby, such as the right-handed operators or left-handed operators. (Fig.3)

- Disconnect the tool from the compressed air supply system.
- Use the wrench 15 mm to unscrew the air inlet end cap along with the o-ring, install the air inlet fitting to the preferable air inlet.
- Fasten the air inlet end cap along with the o-ring to the vacant air inlet firmly.

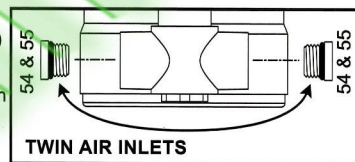

Fig.3

Clean and Replace the Nosepieces

- Disconnect the tool from the compressed air supply system.
- Unscrew the Working Nosepiece (1) from the Head (2), also unscrew other nosepieces from the bottom of the Air Cylinder End Cap (53), clean these nosepieces. Check and replace any worn nosepieces.
- Fasten the Working Nosepiece (1) back to the head firmly, and store other nosepieces to the bottom of the Air Cylinder End Cap (53).

Clean and Replace the Noise Silencer

- Disconnect the tool from the compressed air supply system.
- Unscrew the Noise Silencer Lock Nut (28), take out the Noise Silencer (27) and clean it. If the Noise Silencer (27) is blocked or covered badly, replace it. (Fig.4)
- Reverse the above step to reassemble these two parts. Ensure that the Noise Silencer Lock Nut (28) is fastened firmly.

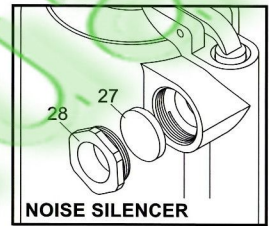

Fig.4

Check, Clean and Replace the Inner Parts of the Jaw Case Assembly, and the Jaws

- Disconnect the tool from the compressed air supply system.
- Unscrew the Head (2) by the Wrench 27 (58), dismantle the Jaw Case Assembly (3AY) by the Wrench 22 (57) and Wrench 27 (58).
- Check all inner parts, any worn or damaged parts and twisted Jaw Pusher Spring (6) should be replaced. Pay attention to check the teeth of Jaws (4), and replace new Jaws (4) if the teeth are worn out. Also pay attention to the Jaw Pusher (5) and Jaw Pusher Spring (6), replace them if they are seriously worn out or become shorter or twisted.
- Use the Brush (56) to clean the Front Jaw Case (3), teeth of Jaws (4), Jaw Pusher (5), Jaw Pusher Spring (6) and Rear Jaw Case (7). Dip these parts into oil for lubrication. For better lubrication, lightly apply the moly-lithium grease on the back side of Jaws (4) and on the inner slope of Front Jaw Case (3). (Fig.5)

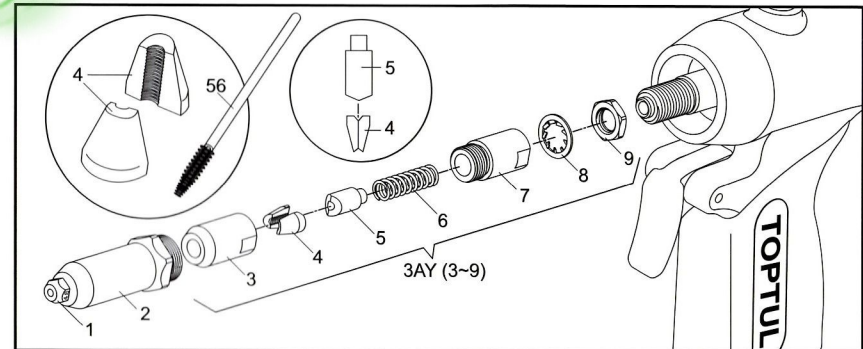

Fig.5

- Reassemble the Lock Nut (9) and put back the Lock Washer (8), reassemble the Rear Jaw Case (7) adjacent to the Lock Washer (8), then put the Jaw Pusher Spring (6) into the Rear Jaw Case (7).
- Carefully put the Jaws (4) into the Front Jaw Case (3) and put the Jaw Pusher (5) to fit the Jaws (4) properly (Fig.6), then fasten these parts to the Rear Jaw Case (7) firmly by the Wrench 22 (57) and Wrench 27 (58). Make sure that the Lock Nut (9) is still not fastened firmly.
- Use the Wrench 22 (57) to check and adjust the Lock Nut (9) to the recommended jaw case assembly distance 60 ± 0.5 mm (Fig.2), at the same time tighten the Rear Jaw Case (7) and the Lock Nut (9) firmly by the Wrench 22 (57) and Wrench 27 (58). Finally, use the Wrench 27 (58) to reassemble the Head (2) firmly.
- Connect the tool to the compressed air supply system. It is suggested to depress the Trigger (30) twice to adjust the inner parts of Jaw Case Assembly (3AY) moving to the normal position, so that the blind rivet mandrel can be inserted into the Working Nosepiece (1) smoothly.

TOPTUL SUPER DUTY AIR HYDRAULIC RIVETER

Read and understand the owner's manual and labels affixed to the tool. Learn its application and limitations as well as the specific potential hazards peculiar to this tool.

Refill Hydraulic Oil Through the Oil Refill Hole

When the shortage of hydraulic oil causes to decrease the stroke, the normal stroke can be recovered by filling the hydraulic oil into the oil refill hole on the top of Oil Cylinder (12).

WARNING:

- Always wear the safety goggles during operation.
- Be sure to disconnect the tool from the compressed air supply system before unscrewing the Oil Screw Plug (14).
- Make sure to tighten the Oil Screw Plug (14) firmly after refilling oil.

1. Connect the tool to the compressed air supply system, depress the Trigger (30) twice to move the inner Oil Piston Assembly (15AY) and Air Piston Assembly (50AY).
2. Disconnect the tool from the compressed air supply system.
3. Push the piston of the Hydraulic Oil Injector (59) forwards to the end, and then immerse the fitting of Hydraulic Oil Injector (59) in the new hydraulic oil and slowly pull the piston backwards to suck the new Hydraulic Oil around 25 ml into the Hydraulic Oil Injector (59). **Make sure that the Hydraulic Oil Injector (59) contains no air bubbles in the oil. (Fig.6)**
4. Carefully unscrew the Oil Screw Plug (14) and remove the Sealing Washer (13).
5. Gently rotate to screw the fitting of Hydraulic Oil Injector (59) into the oil refill hole of Oil Cylinder (12) firmly.
6. Depress the piston of Hydraulic Oil Injector (59) forwards to inject oil until the piston can not move further.
7. Gently unscrew to remove the fitting of Hydraulic Oil Injector (59) from the oil refill hole of Oil Cylinder (12). Wipe away the spill oil, if any.
8. Restore the Sealing Washer (13), and tighten the Oil Screw Plug (14) firmly.
9. Reconnect the tool to the compressed air supply system, depress the trigger twice, the normal stroke is recovered.

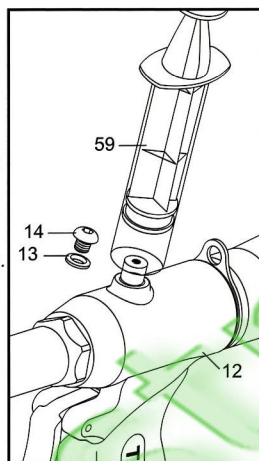

Fig. 6

Replace the O-Rings, Back-Up Rings, Return Springs and Hydraulic Oil

- After considerable times of application, the o-rings and back-up rings of oil cylinder and air cylinder, return springs, also the hydraulic oil should be replaced.
- The hydraulic oil is suggested to use ISO VG-46 or VG-32 that are popular in market.

1. Disconnect the tool from the compressed air supply system.
2. Unscrew the Air Cylinder End Cap (53) & O-Ring (52) with the Wrench 22 (57), use a pair of pliers to slowly pull out the Air Piston Assembly (50AY) in a straight line. (Fig.7)

NOTE:

Be careful not to scratch the Air Piston Rod (49) and the inner wall of Air Cylinder (25).
Drain the dirty hydraulic oil out of the tool.

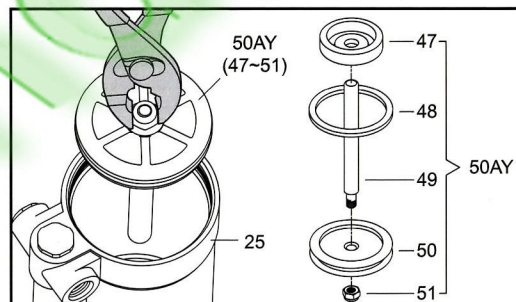

Fig. 7

3. Check and replace the worn Buffer Ring (47), Air Piston Ring (48) and Air Cylinder End Cap O-Ring (52). Also check and replace the worn Air Piston Rod (49) and the damaged Air Piston (50). Finally, check the Air Piston Lock Nut (51) and lock it firmly.
4. Use the Wrench 27 (58) to unscrew the Head (2), only separate the Rear Jaw Case (7) from the Lock Nut (9) and Lock Washer (8) by the Wrench 22 (57) and Wrench 27 (58).
5. Carefully dismantle the Oil Cylinder End Cap (22), remove the Hanging Bracket (21) and Hanging Bracket O-Ring (20), and then take out the Large & Small Return Springs (18 & 19), slowly press the threaded end of Oil Piston (15) to take out the Oil Piston Assembly (15AY). **Pay special attention to dismantle the Oil Cylinder End Cap (22), not to let the strong force of Large & Small Return Springs (18 & 19) jump out to hurt people. Be careful not to scratch the rod of Oil Piston (15) and the inner wall of Oil Cylinder (12).** Check and replace the weak or broken Large & Small Return Springs (18 & 19).
6. Firstly use a long stem socket 35 mm to unscrew the Oil Cylinder Lock Nut (29), use a suitable diameter pin carefully to punch out the Lever Pin (35), and then carefully use a hex wrench 3 mm to unscrew the Lock Screw (26), finally separate the Oil Cylinder (12) from the Air Cylinder (25).
7. **Check and replace the worn Oil Cylinder O-Rings (10), Oil Cylinder Back-Up Rings (11), Oil Piston O-Ring (16), and Oil Piston Back-Up Ring (17). Also check and replace the worn Oil Piston (15).**
8. Grease the inner walls of Oil Cylinder (12) and Air Cylinder (25) (Fig.8), also grease the Oil Piston O-Ring (16) and Air Piston Ring (48). Reverse above steps to reassemble the Oil Cylinder (12) and Air Cylinder (25) together by aligning and using a hex wrench 3 mm to fasten the Lock Screw (26), and then fasten the Oil Cylinder Lock Nut (29) by a long stem socket 35 mm. Finally reassemble the Trigger Lever (32) back to the Air Cylinder (25) by punching the Lever Pin (35) into the original pin holes carefully.
9. Reassemble the Oil Piston Assembly (15AY), Large & Small Return Springs (18 & 19), Oil Cylinder End Cap (22) along with Hanging Bracket (21) and Hanging Bracket O-Ring (20), and the Spent Mandrel Container (24).
10. **Put the tool upside-down, use the oil bottle to refill new hydraulic oil into the Oil Cylinder (12) through the Air Cylinder (25) until oil is flush with the upper Oil Cylinder O-Ring (10). (Fig.9) Make sure not to overfill oil, and rest for a while until the oil stops releasing air bubbles.**
11. Use a pair of pliers to clamp the Air Piston Lock Nut (51), and then slowly plug the Air Piston Assembly (50AY) in a straight line into the Oil Cylinder (12) through the Oil Cylinder Lock Nut (29). (Fig.7) Finally reassemble the Air Cylinder End Cap (53) & O-Ring (52) with the Wrench 22 (57).
12. Use the Wrench 22 (57) and Wrench 27 (58) to reassemble the Lock Nut (9), Lock Washer (8) and Rear Jaw Case (7) together (Fig.5), then use the Wrench 22 (57) and Wrench 27 (58) to adjust and lock the jaw case assembly distance to 60 ± 0.5 mm (Fig.2), finally fasten the Head (2) to the tool. Ensure that the Oil Cylinder End Cap (22) is fastened firmly, the Spent Mandrel Container (24) is fitted well, the Jaw Case Assembly (3AY) and Head (2) are all fastened firmly.

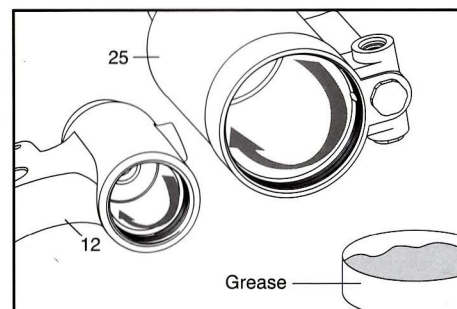

Fig. 8

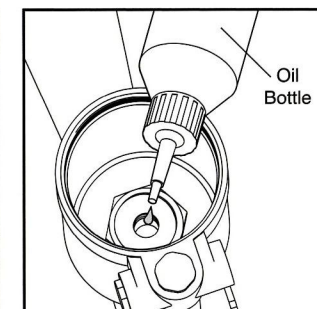

Fig. 9

TOPTUL SUPER DUTY AIR HYDRAULIC RIVETER



Read and understand the owner's manual and labels affixed to the tool. Learn its application and limitations as well as the specific potential hazards peculiar to this tool.

► Dismantle and Replace the Parts of the Trigger Assembly (30AY) and the Valve Assembly (37AY)

- When doing the above **Replace the O-Rings, Back-Up Rings, Return Springs and Hydraulic Oil**, it is suggested to do this replacement at the same time. Follow the **Replace the O-Rings, Back-Up Rings, Return Springs and Hydraulic Oil** Steps 1 - 6 to separate the Oil Cylinder (12) from the Air Cylinder (25). (Fig.10)
- The Lever Pin (35) has been dismantled in the above step, then dismantle the Trigger Assembly (30AY) by using a suitable diameter pin carefully to punch out the Trigger Pin (34) and lower Link Pin (33), finally pull out the Trigger (30) connected with Trigger Link (31) and upper Link Pin (33) from the upper side of Grip (61). Check and replace any worn parts of the Trigger Assembly (30AY).
- Finally dismantle the Valve Assembly (37AY) by unscrewing Valve End Cap (46), carefully take out Valve Assembly (37AY) from two ends, check and replace any worn parts of the Valve Assembly (37AY), such as o-rings, springs, etc.
- Firstly reverse above steps to reassemble Valve Assembly (37AY), then plug the Trigger (30) connected with Trigger Link (31) and upper Link Pin (33) into the upper side of Grip (61), and punch the Trigger Pin (34) and lower Link Pin (33) into the original pin holes, then follow above step to reassemble the Trigger Assembly (30AY).

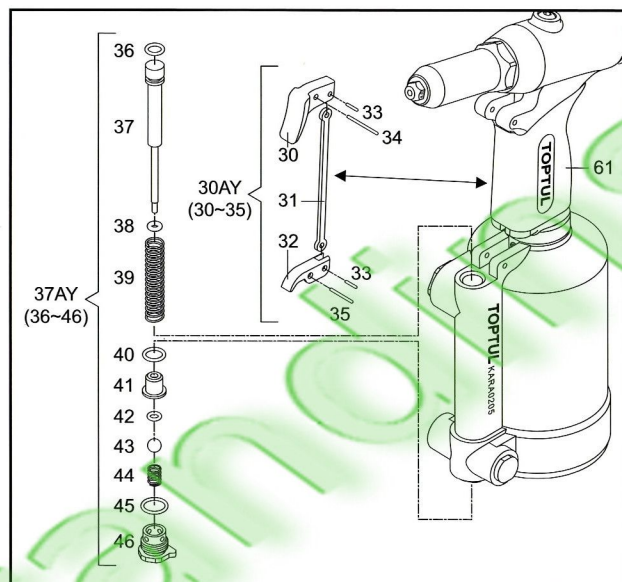

Fig.10

! WARNING

- For multiple hazards, read and understand the safety instructions before installing, operating, repairing, maintaining, changing accessories on, or working near the air power tool. Failure to do so can result in serious bodily injury.
- Only qualified and trained operators should install, adjust or use the air power tool.
- Do not modify this air power tool. Modifications can reduce the effectiveness of safety measures and increase the risks to the operator.
- Do not discard the safety instructions; give them to the operator.
- Do not use the air power tool if it has been damaged.
- The employer/user shall contact the sales representative or manufacturer to obtain replacement marking labels when necessary.
- Failure of the workpiece, accessories or even of the inserted tool itself can generate high-velocity projectiles.
- Always wear impact-resistant eye protection during the operation of the air power tool. The grade of protection required should be assessed for each use.
- Ensure that the workpiece is securely fixed.
- Entanglement hazards can result in choking, scalping or lacerations if loose clothing, personal jewelry, neckwear, hair or gloves are not kept away from the tool and accessories.
- Gloves can become entangled with the rotating drive and cause severed or broken fingers.
- Rotating drive sockets and drive extensions can easily entangle rubber-coated or metal-reinforced gloves.
- Do not wear loose-fitting gloves or frayed, cut glove.
- Check that the means of protection from ejection of fastener and / or stem is in place and is operative.
- There is possibly forcible ejection of installation mandrels from the front of the assembly power tool.
- The use of the tool can expose the operator's hands to hazards including crushing, impacts, cuts, abrasions and heat. Wear suitable gloves to protect hands.
- Operators and maintenance personnel shall be physically able to handle the bulk, weight and power of the tool.
- Hold the tool correctly; be ready to counteract normal or sudden movements and have both hands available.
- Maintain a balanced body position and secure footing.
- If the assembly power tool is fixed to a suspension device, make sure that the fixation is secure.
- Avoid unsuitable postures, as it is likely for these positions not to allow counteracting of normal or unexpected movement of the tool.
- Tools shall be inspected periodically to verify that the ratings and markings required, by this part of ISO 11148 are legibly marked on the tool, and that listed in this manual.
- Release the start-and-stop device in the case of an interruption of the energy supply.
- Use only lubricants recommended by TOPTUL's authorized sales or service representatives.
- Do not use in confined spaces and beware of crushing hands between tool and workpiece.
- Keep others a safe distance from your work area, or ensure they use appropriate personal protective equipment.
- When using a power tool for the operator can experience discomfort in the hands, arms, shoulders, neck or other parts of the body.
- While using an air power tool, the operator should adopt a comfortable posture while maintaining secure footing and avoiding awkward or off-balanced postures.
- While using an air power tool, the operator should change posture during extended tasks, which can help avoid discomfort and fatigue.
- If the operator experiences symptoms such as persistent or recurring discomfort, pain, throbbing, aching, tingling, numbness, burning sensations or stiffness. These warning signs should not be ignored. The operator should tell the employer and consult a qualified health professional.
- Disconnect the air power tool from the energy supply before changing the inserted tool or accessory.
- Use only types and sizes of accessories and consumables that are recommended by TOPTUL's authorized sales or service representatives.
- Slips, trips and falls are major causes of workplace injury.
- Be aware of slippery surfaces caused by the use of the tool and also of trip hazards caused by the air line or hydraulic hose.
- Proceed with care in unfamiliar surroundings. Hidden hazards, such as electricity or other utility lines can exist.
- The air power tool is not intended for use in potentially explosive atmospheres and is not insulated against coming into contact with electric power.
- Make sure there are no electrical cables, gas pipes and others in the workplace. The use of air power tool can damage the equipment and cause a potential hazard.
- Use of air power tools can generate dusts and fumes and cause ill health (for example, cancer, birth defects asthma and/or dermatitis); risk assessment and implementation of appropriate controls for these hazards are essential.
- Risk assessment should include dust generated by the use of the tool; the dust can disturb the operator and cause a potential hazard.

TOPTUL SUPER DUTY AIR HYDRAULIC RIVETER



Read and understand the owner's manual and labels affixed to the tool. Learn its application and limitations as well as the specific potential hazards peculiar to this tool.

40. Direct the exhaust away from the operator so as to minimize disturbance of dust in a dust-filled environment.
41. Where dust or fumes are generated, the priority shall be to control them at the point of emission.
42. All integral features or accessories for the collection, extraction or suppression of airborne dust or fumes should be correctly used and maintained in accordance with the manufacturer's instructions.
43. Use respiratory protection in accordance with employer's instructions and as required by occupational health and safety regulations.
44. Unprotected exposure to high noise levels can cause permanent and disabling hearing loss and other problems, such as tinnitus ringing, buzzing, whistling or humming in the ears. Risk assessment and implementation of appropriate controls for these hazards are essential.
45. Appropriate controls to reduce the risk may include actions such as damping materials to prevent workpiece from "ringing".
46. Use hearing protection in accordance with employer's instructions and as required by occupational health and safety regulations.
47. Operate and maintain the air power tool as recommended in the instruction handbook in order to prevent an unnecessary increase in noise levels.
48. If the assembly air power tool for threaded fasteners has a silencer, always ensure it is in place and in good working order when operating.
49. Select, maintain and replace the consumable/inserted tool as recommended in the instruction handbook in order to prevent an unnecessary increase in noise.
50. Exposure to vibration can cause disabling damage to the nerves and blood supply of the hands and arms.
51. Wear warm clothing when working in cold conditions and keep your hands warm and dry.
52. If you experience numbness, tingle, pain or whitening of the skin in your fingers or hands, stop using the assembly air power tool for threaded fasteners, talk to your employer and consult a physician.
53. Operate and maintain the assembly air power tool for threaded fasteners as recommended in the instruction handbook in order to prevent an unnecessary increase in vibration levels.
54. Select, maintain and replace the consumable/inserted tool as recommended in the instruction handbook in order to prevent an unnecessary increase in vibration levels.
55. Support the weight of the tool in a stand, tensioner or balancer if possible.
56. Hold the tool with a light but safe grip, taking account of the required hand reaction forces because the risk from vibration is generally greater when the grip force is higher.
57. Air under pressure can cause severe injury.
58. Always shut off air supply, drain hose of air pressure and disconnect tool from air supply when not in use before changing accessories or when making repairs.
59. Never direct air at yourself or anyone else.
60. Whipping hoses can cause severe injury.
61. Always check for damaged or loose hoses and fittings.
62. Cold air shall be directed away from the hands.
63. Whenever universal twist couplings (claw couplings) are used, lock pins shall be installed and whipcheck safety cables shall be used to safeguard against possible hose-to-tool and hose-and-hose connection failure.
64. Do not exceed the maximum air pressure stated on the tool.
65. Never carry an air power tool by the hose.
66. The limitations of environmental conditions on Tool are the temperature 0~40°C (32~104°F), and Tool can not be used in the water.
67. Tool weight over 2.0 kg or 4.4 lb is suggested to be supported by two hands, one hand to hold handle grip and the other hand to support the bottom of Tool, whilst lifting or operating Tool.
68. Setting up or fixing the air power tool in a stable position. The tool can also be appropriately mounted in a support.
69. Keep the air power tools safe by regular preventative maintenance.
70. Check the speed and make a simple check of the vibration level after each service.
71. Check the speed regularly.
72. The working places shall keep ventilated, clean and illuminated.
73. Do not lubricate tools with flammable or volatile liquids such as kerosene, diesel or jet fuel.
74. Any other use of this air power tool other than its designated purpose is prohibited.

SAFETY INSTRUCTIONS

1. The tool must be checked and maintained in a safe working condition at all times.
2. Do not use the tool outside the intent of design and use.
3. Do not dismantle the tool without prior reference to this manual.
4. Any modification to the tool and tool parts shall be prohibited.
5. Always use original spare parts to ensure safe operation and satisfactory performance.
6. Be sure to disconnect the tool from air line before attempting to adjust, change nosepiece or dismantle tool's parts.
7. For safety work, the operator and other persons in the vicinity are always required to wear the safety goggles to protect against spent mandrel ejection.
8. Be sure to adopt a firm footing or stable position before and during operating the tool.
9. Do not point the tool towards any person(s) or operator.
10. Do not operate the tool without firmly installing the Jaw Case Assembly (3AY) including Front Jaw Case (3), Rear Jaw Case (7), Lock Washer (8) and Lock Nut (9), the Head (2) and Working Nosepiece (1), and the Spent Mandrel Container (24).
11. Do not operate the tool without firmly locking the Oil Screw Plug & Sealing Washer (14 & 13), Oil Cylinder End Cap (22), Noise Silencer Lock Nut (28), Valve End Cap (46), Air Cylinder End Cap (53) and Air Inlet End Cap (55).
12. Be sure to properly adjust the JAW CASE ASSEMBLY DISTANCE to be 60±0.5 mm.
13. The Operating Air Pressure shall not exceed 6.5 bar or 95 psi.
14. Excessive priming of hydraulic oil in the tool should be avoided.
15. After setting each blind rivet, the spent mandrel must be cleared out into the Spent Mandrel Container (24) by tilting Head (2) upwards, so that the spent mandrels shall be not jammed in the tool after setting the next blind rivet.
16. Take care to ensure the mandrel's sharp end and spent mandrels are not to create any hazards.
17. Ensure that Noise Silencer (27) and vent holes do not become blocked or covered, and that air hose is always in good condition.
18. Always keep the tool and Grip (61) dry and clean for the best possible grip and operation.
19. Take care to avoid entanglement of loose clothes, ties, long hair, cleaning rags, etc. In the moving parts of the tool.
20. When carrying the tool from place to place, always keep hands away from the trigger to avoid inadvertent start up.
21. Take care to use the tool. Do not drop the tool. Do not use the tool as a hammer or other uses that will damage and wear the tool.
22. The tool should be examined at regular intervals for function and damage. Any question regarding the correct operation of tool and operator safety should consult the manufacturer, authorized local agent or distributor.

EC DECLARATION OF CONFORMITY

Herewith declares that : The product listed on the table above are manufactured and tested according to the following standards Safety Standard According to **ISO 11148-1:2011** and are in conformity with the provisions of the Machinery Directive 2006/42/EC and with National Implementing Legislation.



Air Hydraulic Riveter
 ITEM NO. **KARA0205**

SPECIFICATIONS TABLE

Item NO.	Rivet Diameter	Stroke		Power		Overall Length		Air Inlet	Air Hose	Air Consumption Per Rivet	Net Weight		Noise Level	Vib.	Exhaust
		inch	mm	lbf	N	inch	mm	PT	I.D.	CFM	lbs	kgs	DB	M/S ²	
KARA0205	2.4, 3.0/3.2, 4.0, 4.8/5.0 mm (3/32", 1/8", 5/32", 3/16")	0.71	18	2,000	9,000	10-5/8	270	1/4	5/16	2.5	3.92	1.78	87.2	<2.5	Side

• Includes four standard nosepieces: 2.4, 3.0/3.2, 4.0, 4.8/5.0 mm or 3/32", 1/8", 5/32", 3/16"
 • The uncertainty in the sound levels is 3 dB(A)

ROTAR MACHINERY INDUSTRIAL CO., LTD.
 No.189, Gongye Rd., Taiping Dist., Taichung City 41154
 (Ta Li Ind. Park), Taiwan
 Tel:+886-4-22715989 (Rep) Fax:+886-4-22716979
 E-Mail:service@toptul.com

Lawrence
 Q.C. DIRECTOR



GENERAL TROUBLESHOOTING GUIDE

SYMPTOM	POSSIBLE CAUSES	CORRECTIVE ACTION
1. Blind rivet mandrel fails to insert into Working Nosepiece.	Wrong size Nosepiece (1).	Change a correct size Nosepiece (1).
	Loose Working Nosepiece (1).	Tighten Working Nosepiece (1).
	Dust accumulated in Nosepiece (1).	Clean Nosepiece (1).
	Worn Nosepiece (1).	Replace a new Nosepiece (1).
	Loose Head (2).	Tighten Head (2).
	Improper assembly of Jaw Case Assembly (3AY).	Reassemble Jaw Case Assembly (3AY).
	Dust accumulated in Jaw Case Assembly (3AY).	Clean Jaw Case Assembly (3AY) parts.
	Worn Jaw Pusher (5).	Replace a new Jaw Pusher (5).
	Weak or broken Jaw Pusher Spring (6).	Replace a new Jaw Pusher Spring (6).
	Weak or broken Return Springs (18 & 19).	Replace new Return Springs (18 & 19).
	Insufficient Jaw Case Assembly (3AY) distance.	Adjust to normal distance 60±0.5 mm.
	Air Piston Assembly (50AY) stuck in Air Cylinder (25).	See below 6. Slow operation or no operation of Air Piston Assembly (50AY) in Air Cylinder (25) solutions.
	Spent mandrels jammed in the tool.	Clean to eject spent mandrels.
Spent Mandrel Container (24) is full.	Empty Spent Mandrel Container (24).	
2. Tool fails to bite or break blind rivet mandrel.	Wrong size Nosepiece (1).	Change a correct size Nosepiece (1).
	Dust accumulated in Jaws (4).	Clean Jaws (4).
	Worn or broken Jaws (4) and Jaw Pusher (5).	Replace new Jaws (4) and Jaw Pusher (5).
	Weak or broken Jaw Pusher Spring (6).	Replace a new Jaw Pusher Spring (6).
	Loose Front Jaw Case (3) and Rear Jaw Case (7).	Tighten Front Jaw Case (3) and Rear Jaw Case (7).
	Dust accumulated in Jaw Case Assembly (3AY).	Clean Jaw Case Assembly (3AY) parts.
	Loose Head (2).	Tighten Head (2).
	Dust accumulated in Head (2).	Clean the inside of Head (2).
	Low air pressure or air pressure lost.	Check compressed air supply system, adjust air pressure to in specification, check Air Cylinder (25) leak and replace it if necessary, clean Air Cylinder (25) inside, clean or replace O-Rings (48, 52, 54).
	Hydraulic oil pressure lost.	Insufficient oil and refill oil, check Oil Cylinder (12) leak and replace it if necessary, replace all O-Rings (10, 16, 20) and Back-Up Rings (11, 17).
Exceed tool's capacity.	Use more powerful tool.	

SYMPTOM	POSSIBLE CAUSES	CORRECTIVE ACTION
3. Spent mandrel can't be ejected after setting blind rivet.	Wrong size Working Nosepiece (1).	Change a correct size Working Nosepiece (1).
	Dust accumulated in Jaw Case Assembly (3AY).	Clean Jaw Case Assembly (3AY) parts.
	Spent mandrels jammed in tool.	Clean to eject spent mandrels.
	Spent Mandrel Container (24) is full.	Empty Spent Mandrel Container (24).
	Air Piston Assembly (50AY) stuck in Air Cylinder (25) and fails to return to its normal position.	See below 6. Slow operation or no operation of Air Piston Assembly (50AY) in Air Cylinder (25) solutions.
4. Slow cycle.	Low air pressure.	Check compressed air supply system, adjust air pressure to in specification, check Air Cylinder (25) leak and replace it if necessary, clean Air Cylinder (25) inside, clean or replace O-Rings (48, 52, 54).
	Dust accumulated in Jaw Case Assembly (3AY).	Clean Jaw Case Assembly (3AY) parts.
	Dust accumulated in Head (2).	Clean the inside of Head (2).
5. No operation after triggering (stroke lost), or more than one operation of trigger to fasten blind rivet (stroke decreased).	Rivet Body is too long.	Check suitable rivet body length to match work pieces' thickness. It is nothing to do with stroke.
	Low air pressure.	Check compressed air supply system, adjust air pressure to in specification, check Air Cylinder (25) leak and replace it if necessary, clean Air Cylinder (25) inside, clean or replace O-Rings (48, 52, 54).
	Improper assembly of Jaw Case Assembly (3AY).	Reassemble Jaw Case Assembly (3AY).
	Dust accumulated in Jaw Case Assembly (3AY).	Clean Jaw Case Assembly (3AY) parts.
	Dust accumulated in Jaws (4).	Clean Jaws (4).
	Worn or broken Jaws (4), Jaw Pusher (5), Jaw Pusher Spring (6).	Replace new Jaws (4), Jaw Pusher (5), Jaw Pusher Spring (6).
	Overlong jaw case assembly distance.	Adjust to normal distance 60±0.5 mm.
	Insufficient hydraulic oil leads to stroke.	Refill hydraulic oil through oil refill hole.
	Air bubbles in hydraulic oil.	Suck air bubbles from oil refill hole by Hydraulic Oil Injector (59), or bleed Oil from Air Cylinder (25), and refill new hydraulic oil.
	Oil Cylinder (12) leaks.	See 7. Oil Cylinder (12) leaks hydraulic oil.
	Improper assembly of Valve Assembly (37AY).	Reassemble Valve Assembly (37AY).
	Worn o-rings in Valve Assembly (37AY).	Replace all O-Rings (36, 38, 40, 42, 45).

SYMPTOM	POSSIBLE CAUSES	CORRECTIVE ACTION
6. Slow operation or no operation of Air Piston Assembly (50AY) in Air Cylinder (25).	Improper assembly of Valve Assembly (37AY).	Reassemble Valve Assembly (37AY).
	Worn o-rings in Valve Assembly (37AY).	Replace all O-Rings (36, 38, 40, 42, 45).
	Low air pressure.	Check compressed air supply system, adjust air pressure to in specification, check Air Cylinder (25) leak and replace it if necessary, clean Air Cylinder (25) inside, clean or replace O-Rings (48, 52, 54).
	Noise Silencer (27) blocks air exhaust.	Clean or replace a new Noise Silencer (27).
	Weak or broken Return Springs (18 & 19).	Replace new Return Springs (18 & 19).
	Oil Cylinder (12) damaged.	Replace a new Oil Cylinder (12).
7. Oil Cylinder (12) leaks hydraulic oil.	Improper assembly of O-Rings (10, 16, 20) and Back-Up Rings (11, 17) in front & rear ends of Oil Cylinder (12).	Reassemble O-Rings (10, 16, 20) and Back-Up Rings (11, 17) in front & rear ends of Oil Cylinder (12).
	Worn O-Rings (10, 16, 20) and Back-Up Rings (11, 17) in front & rear ends of Oil Cylinder (12).	Replace new O-Rings (10, 16, 20) and Back-Up Rings (11, 17) in front & rear ends of Oil Cylinder (12).
8. Air Cylinder (25) and Noise Silencer (27) leak hydraulic oil.	Improper assembly of O-Rings (10) and Back-Up Ring (11) in lower end of Oil Cylinder (12).	Reassemble O-Rings (10) and Back-Up Ring (11) in lower end of Oil Cylinder (12).
	Worn O-Rings (10) and Back-Up Ring (11) in lower part of Oil Cylinder (12).	Replace new O-Rings (10) and Back-Up Ring (11) in lower end of Oil Cylinder (12).
9. Valve Assembly (37AY) and Noise Silencer (27) leak air.	Improper assembly of Valve Assembly (37AY).	Reassemble Valve Assembly (37AY).
	Worn O-Rings (36, 38, 40, 42, 45) in Valve Assembly (37AY).	Replace new O-Rings (36, 38, 40, 42, 45) in Valve Assembly (37AY).
	Weak Springs (39, 44) in Valve Assembly (37AY).	Replace new Springs (39, 44) in Valve Assembly (37AY).
10. Air inlet and air inlet fitting leak air.	Wrong thread size of air inlet fitting.	Change correct thread size of air inlet fitting.
	Air Inlet thread damaged.	Tap thread and wrap tape seal around air inlet fitting's male thread.